



Uniclass L725111	EPIC G611
CI/SFB (74.26)	X

DATA

Thermostatic & Pressure Balanced Mixing Valve
 Concealed supply with Riser Kit
 Maximum Temperature 90°
 Minimum Pressure 0.2 Bar
 Maximum Pressure 12 Bar
 Pressure Differential 10 Bar
 Normal Control Temperature 38°
 Output Temp Differential +/- 1°c
 Max Output 8 l/pm @ 6 Bar

MATERIALS

Mixer Body BZR Brass With Chrome Finish
 Handles ABS Plastic
 Connections Inlet Valve Body G3/4 F BSP

FEATURES

Thermostatic & Pressure Balanced Cartridges constant temp regardless of pressure variations
 Anti Scald cut off 0.02 seconds
 Water Saving Showerhead or Single Function
 Quick & Easy to fit & maintain
 NRV Fitted to Hot & Cold Inlets
 We recommend the use of isolating ball valves with our units

SPEC CODES

Mixer 9215-0000
 Fixing Bracket 9205-2050
 NCAGE No KC1U7

APPROVALS

WRAS DO8 TMV3 ISO9001 ISO 14002

APPLICATION

Multi user and multi floor applications. Hospital, hotels, accommodation blocks, halls of residence, barracks, gymnasiums.

FMM 04 Kit

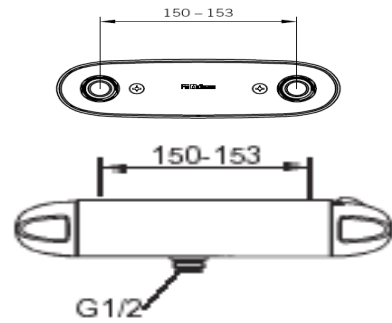
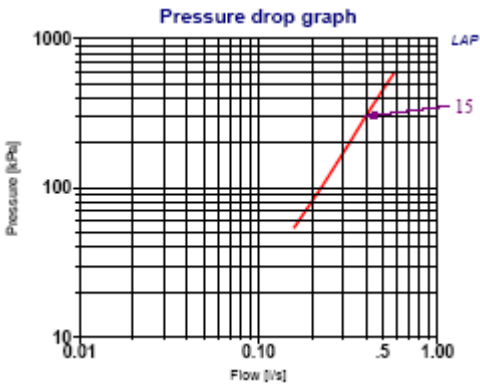

**10 YEAR
PRESSURE
GUARANTEE**
FM Mattsson

**10 YEAR
CALCIUM
GUARANTEE**
FM Mattsson

**10 YEAR
TEMPERATURE
GUARANTEE**
FM Mattsson

☎ 0870 7657987

🌐 www.alchallis.com

@ info@alchallis.com

